

Standby Power Rating

20 kW 60 Hz

Liquid Cooled
Gas Engine
Generator Sets



WHISPER-TEST™

Whisper-Test™

Low Speed Exercise
62 dB(A) at 23 feet

GENERAC 1.6L ENGINE

Naturally Aspirated
Gaseous Fueled

UL 2200 Listed

Transfer Switch is sold separately

STANDARD EQUIPMENT

- All input connections in one single area
- High coolant temperature shutdown
- Low oil pressure shutdown
- Low coolant level automatic shutdown
- Overspeed automatic shutdown
- Crank timer
- Exercise timer
- Oil drain extension
- Cool flow radiator
- Closed coolant recovery system
- UV/Ozone resistant hoses
- Watertight state of the art electrical connectors
- Mainline circuit breaker
- Radiator drain extension
- Battery charge alternator
- 2 Amp static battery charger
- Battery rack and battery cables
- Fan and belt guards
- Isochronous governor
- Flex fuel line pigtail

FEATURES

- Innovative design and fully prototype tested
- UL 2200 Listed
- Solid state frequency compensated voltage regulator
- Dynamic and static battery charger
- Sound attenuated acoustically designed enclosure
- *Whisper-Test™* feature for low noise level exercise
- Acoustically designed engine cooling system
- High flow, low noise factory engineered exhaust system
- State of the art control system with R-Series digital control panel
- Watertight electrical connectors
- Rodent proof construction
- High efficiency, low distortion Generac designed alternator
- Vibration isolated from mounting base
- Matching Generac transfer switches engineered and tested to work as a system
- All components easily accessible for maintenance
- Electrostatically applied powder paint

GUARDIAN Elite™
by Generac Power Systems, Inc.

COMMERCIAL SERIES

GENERATOR SPECIFICATIONS

TYPE.....	Synchronous
ROTOR INSULATION.....	Class F
STATOR INSULATION.....	Class F
TOTAL HARMONIC DISTORTION.....	<5%
TELEPHONE INTERFERENCE FACTOR (TIF).....	<50
ALTERNATOR OUTPUT LEADS 3 PHASE.....	4 wire
BEARINGS.....	Sealed Ball
COUPLING.....	Flexible Disc
LOAD CAPACITY (STANDBY RATING).....	20 kW
EXCITATION SYSTEM.....	Direct

NOTE: Generator rating and performance in accordance with ISO8528-5, BS5514, SAE J1349, ISO3046, and DIN6271 standards.

VOLTAGE REGULATOR

TYPE.....	Electronic
SENSING.....	Single Phase
REGULATION.....	± 1%
FEATURES.....	V/F Adjustable Adjustable Voltage and Gain LED Indicators

GENERATOR FEATURES

- Revolving field heavy duty generator
- Directly connected to the engine
- Operating temperature rise 120 °C above a 40 °C ambient
- Insulation is Class F rated at 130 °C rise
- All models are fully prototyped tested

CONTROL PANEL FEATURES

- SEVEN LED INDICATOR LIGHTS
 - System ready
 - Low fuel pressure
 - Low battery
 - Low oil pressure
 - High coolant temp/low coolant temp
 - Overspeed
 - Overcrank
- ADDITIONAL FUNCTIONS
 - Utility sensing
 - Delay on utility failure for engine start
 - Engine warm up before transfer
 - Delay to retransfer to utility
 - Engine cool down timer
 - Exerciser not set
- INTERNAL FUNCTIONS:
 - 3 position switch (auto, off and manual)
 - 2 wire start for any transfer switch
 - Communicates with the Generac RTS transfer switch
 - Built-in 7 day exerciser
 - Selectable engine speed at exercise
 - Governor controller is built into the master control board
 - Temperature range -40 °C to 70 °C

ENGINE SPECIFICATIONS

MAKE.....	Generac
MODEL.....	In line
CYLINDERS.....	4
DISPLACEMENT.....	1.6 Liter
BORE.....	3.15
STROKE.....	3.13
COMPRESSION RATIO.....	9.75:1
INTAKE AIR SYSTEM.....	Naturally Aspirated
VALVE SEATS.....	Replaceable
LIFTER TYPE.....	Hydraulic

GOVERNOR SPECIFICATIONS

TYPE.....	Electronic
FREQUENCY REGULATION.....	Isosynchronous
STEADY STATE REGULATION.....	± 0.25
ADJUSTMENTS	
Speed.....	Yes
Droop.....	Yes

ENGINE LUBRICATION SYSTEM

OIL PUMP.....	Gear
OIL FILTER.....	Full flow spin-on cartridge
CRANKCASE CAPACITY.....	4 Quarts

ENGINE COOLING SYSTEM

TYPE.....	Closed
WATER PUMP.....	Belt driven
FAN SPEED.....	2550
FAN DIAMETER.....	15 inches
FAN MODE.....	Pusher

FUEL SYSTEM

FUEL TYPE.....	Natural gas, propane vapor
CARBURETOR.....	Down Draft
SECONDARY FUEL REGULATOR.....	Standard
FUEL SHUT OFF SOLENOID.....	Standard
OPERATING FUEL PRESSURE.....	.5" - 14" H ₂ O

ELECTRICAL SYSTEM

BATTERY CHARGE ALTERNATOR.....	12V 30 Amp
STATIC BATTERY CHARGER.....	2 Amp
RECOMMENDED BATTERY.....	Group 26, 525 CCA
SYSTEM VOLTAGE.....	12 Volts

Rating definitions - Standby: Applicable for supplying emergency power for the duration of the utility power outage. No overload capability is available for this rating. (All ratings in accordance with BS5514, ISO3046 and DIN6271). (All ratings in accordance with BS5514, ISO3046, ISO8528 and DIN6271).

OPERATING DATA

	STANDBY 20 kW		
KW RATING	20		
ENGINE SIZE	1.6 Liter 4 cyl. inline		
GENERATOR OUTPUT VOLTAGE/KW - 60 Hz 120/208V, 3-phase, 0.8 pf 120/240V, 3-phase, 0.8 pf	KW 20 20	AMP 69 60.2	CB Size 80 70
GENERATOR LOCKED ROTOR KVA AVAILABLE @ VOLTAGE DIP OF 35% 208 or 240V 3-phase	34		
ENGINE FUEL CONSUMPTION (Natural Gas) (Propane)	Natural Gas (ft ³ /hr.)	Propane (gal/hr.) cu ft/hr	
Exercise cycle	60	0.65	24
25% of rated load	124	1.35	49
50% of rated load	188	2.05	75
75% of rated load	250	2.73	99
100% of rated load	315	3.44	125
ENGINE COOLING			
Air flow (inlet air including alternator and combustion air)	ft ³ /min.	1,528	
System coolant capacity	US gal.	2.0	
Heat rejection to coolant	BTU/hr.	107,000	
Max. operating air temp. on radiator	°C (°F)	60 (150)	
Max. ambient temperature	°C (°F)	50 (140)	
COMBUSTION AIR REQUIREMENTS			
Flow at rated power 60 Hz	cfm	91	
SOUND EMISSIONS IN DBA			
db(A) @ 23 feet in exercise mode		62	
db(A) @ 23 feet at normal operating load		74	
EXHAUST			
Exhaust flow at rated output 60 Hz	cfm	177	
Exhaust temp. at muffler outlet	°F	910	
ENGINE PARAMETERS			
Rated synchronous RPM	60 Hz	3600	
HP at rated KW	60 Hz	34.8	
POWER ADJUSTMENT FOR AMBIENT CONDITIONS			
Temperature Deration			
	3% for every 10 °C above - °C	40	
	1.65% for every 10 °F above - °F	104	
Altitude Deration			
	1% for every 100 m above - m	914	
	3% for every 1000 ft. above - ft.	3000	

RATING: All three phases units are rated at 0.8 power factor. All single phase units are rated at 1.0 power factor. STANDBY RATING: Standby ratings apply to installations served by a reliable utility source. The standby rating is applicable to varying loads for the duration of a power outage. There is no overload capability for this rating. Ratings are in accordance with ISO-3046-1. Design and specifications are subject to change without notice. Maximum wattage and current are subject to and limited by such factors as fuel, Btu content, ambient temperature, altitude, engine power and condition, etc.

INTERCONNECTIONS

COMMERCIAL 20 KW

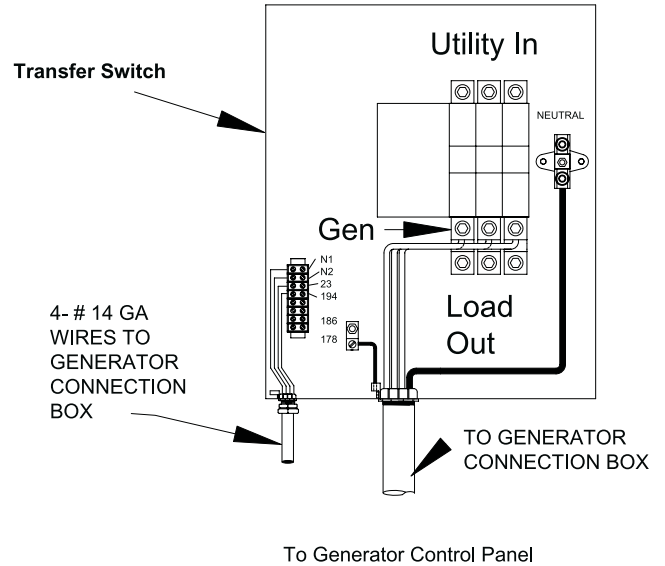
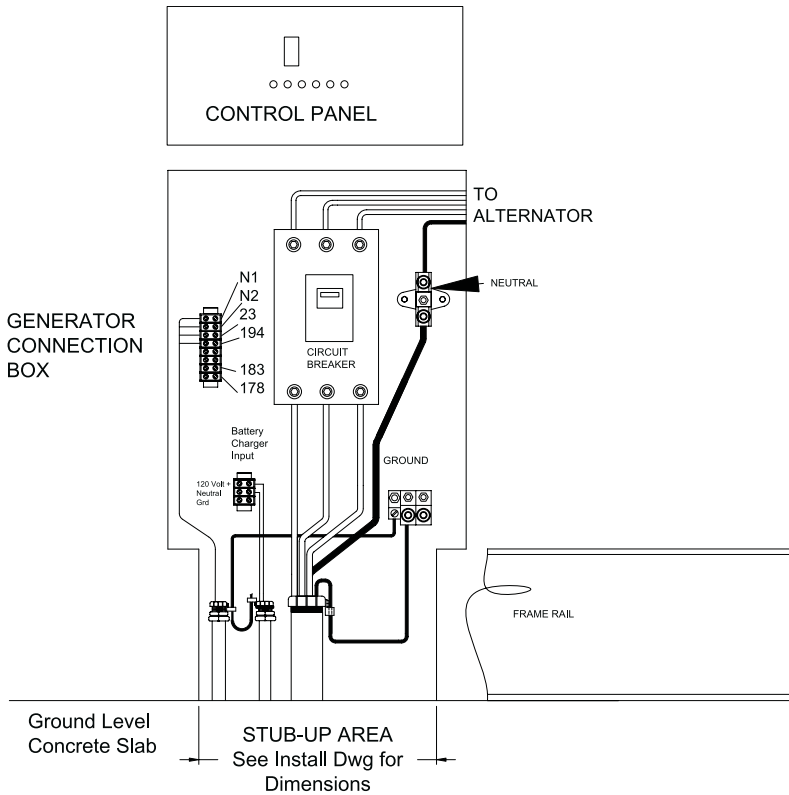

KW	CIRCUIT BREAKER SIZE		
	VOLTS	/ AMPS	LUG SIZE
20	208 3 Ø	80	#4 to 1/0
20	240 3 Ø	70	#4 to 1/0

INSTALLATION LAYOUT

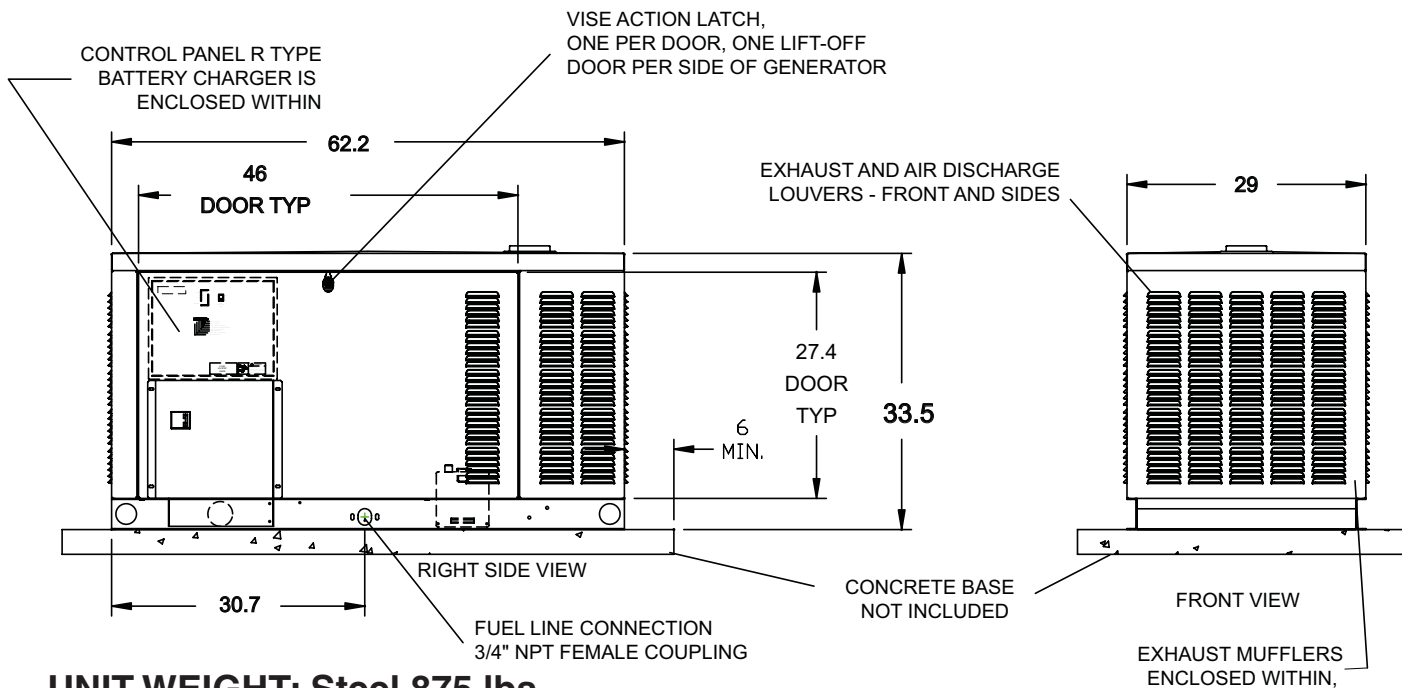

UNIT WEIGHT: Steel 875 lbs.

GENERAC® POWER SYSTEMS, INC. • P.O. BOX 297 • WHITEWATER, WI 53190
WEBSITE: www.guardiangenerators.com