

# Standby Power Rating

## 45 kW 60 Hz

Liquid Cooled  
Gas Engine  
Generator Sets



**WHISPER-TEST™**



**Whisper-Test™**

Low Speed Exercise  
58 dB(A) at 23 feet

**GENERAC 2.4L ENGINE**

Naturally Aspirated  
Gaseous Fueled

UL 2200 Listed

Transfer Switch is sold separately

## STANDARD EQUIPMENT

- All input connections in one single area
- High coolant temperature shutdown
- Low oil pressure shutdown
- Low coolant level automatic shutdown
- Overspeed automatic shutdown
- Crank timer
- Exercise timer
- Oil drain extension
- Cool flow radiator
- Closed coolant recovery system
- UV/Ozone resistant hoses
- Watertight state of the art electrical connectors
- Mainline circuit breaker
- Radiator drain extension
- Battery charge alternator
- 2 Amp static battery charger
- Battery rack and battery cables
- Fan and belt guards
- Isochronous governor
- Flex fuel line pigtail

## FEATURES

- Innovative design and fully prototype tested
- UL 2200 Listed
- Solid state frequency compensated voltage regulator
- Dynamic and static battery charger
- Sound attenuated acoustically designed enclosure
- Whisper-Test™ for low noise level exercise
- Acoustically designed engine cooling system
- High flow low noise factory engineered exhaust system
- State of the art control system with R-Series digital control panel
- Rodent proof construction
- High efficiency, low distortion Generac designed alternator
- Vibration isolated from mounting base
- Matching Generac transfer switches engineered and tested to work as a system
- All components easily accessible for maintenance
- Electrostatically applied textured powder paint

**GUARDIAN Elite™**  
by Generac Power Systems, Inc.

**COMMERCIAL SERIES**

## GENERATOR SPECIFICATIONS

TYPE.....	Synchronous
ROTOR INSULATION.....	Class H
STATOR INSULATION.....	Class H
TOTAL HARMONIC DISTORTION.....	<5%
TELEPHONE INTERFERENCE FACTOR (TIF).....	<50
ALTERNATOR OUTPUT LEADS 3 PHASE.....	4 wire
BEARINGS.....	Sealed Ball
COUPLING.....	Flexible Disc
LOAD CAPACITY (STANDBY RATING).....	45 kW
EXCITATION SYSTEM.....	Direct

NOTE: Generator rating and performance in accordance with ISO8528-5, BS5514, SAE J1349, ISO3046, and DIN6271 standards.

## VOLTAGE REGULATOR

TYPE.....	Electronic
SENSING.....	Single Phase
REGULATION.....	± 1%
FEATURES.....	V/F Adjustable Adjustable Voltage and Gain LED Indicators

## GENERATOR FEATURES

- Revolving field heavy duty generator
- Directly connected to the engine
- Operating temperature rise 120 °C above a 40 °C ambient
- Insulation is Class H rated at 150 °C rise
- All models are fully prototyped tested

## CONTROL PANEL FEATURES

- |  |   |
|--|---|
| <ul style="list-style-type: none"> <li><input type="checkbox"/> SEVEN LED INDICATOR LIGHTS                     <ul style="list-style-type: none"> <li>• System ready</li> <li>• Low fuel pressure</li> <li>• Low battery</li> <li>• Low oil pressure</li> <li>• High coolant temp/low coolant temp</li> <li>• Overspeed</li> <li>• Overcrank</li> </ul> </li> <li><input type="checkbox"/> INTERNAL FUNCTIONS:                     <ul style="list-style-type: none"> <li>• 3 position switch (auto, off and manual)</li> <li>• 2 wire start for any transfer switch</li> <li>• Communicates with the Generac RTS transfer switch</li> <li>• Built-in 7 day exerciser</li> <li>• Selectable engine speed at exercise</li> <li>• Governor controller is built into the master control board</li> <li>• Temperature range -40 °C to 70 °C</li> </ul> </li> </ul> | <ul style="list-style-type: none"> <li><input type="checkbox"/> ADDITIONAL FUNCTIONS                     <ul style="list-style-type: none"> <li>• Utility sensing</li> <li>• Delay on utility failure for engine start</li> <li>• Engine warm-up before transfer</li> <li>• Delay to retransfer to utility</li> <li>• Engine cooldown timer</li> <li>• Exerciser not set</li> </ul> </li> </ul> |
|--|---|

## ENGINE SPECIFICATIONS

MAKE.....	Generac
MODEL.....	Inline 4
CYLINDERS.....	4
DISPLACEMENT.....	2.4 Liter, 146 cu. in.
BORE.....	3.41
STROKE.....	3.94
COMPRESSION RATIO.....	8.5:1
INTAKE AIR SYSTEM.....	Naturally Aspirated
VALVE SEATS.....	Precision ground
LIFTER TYPE.....	Overhead Valve Push Rod, Hydraulic

## GOVERNOR SPECIFICATIONS

TYPE.....	Electronic
FREQUENCY REGULATION.....	Isosynchronous
STEADY STATE REGULATION.....	± 0.25%

## ENGINE LUBRICATION SYSTEM

OIL PUMP.....	Gear
OIL FILTER.....	Full flow spin-on cartridge
CRANKCASE CAPACITY.....	4 Quarts

## ENGINE COOLING SYSTEM

TYPE.....	Pressurized Closed
WATER PUMP.....	Belt driven
FAN SPEED.....	2060
FAN DIAMETER.....	22 inches
FAN MODE.....	Pusher

## FUEL SYSTEM

FUEL TYPE.....	Natural gas, propane vapor
CARBURETOR.....	Down Draft
SECONDARY FUEL REGULATOR.....	Standard
FUEL SHUT OFF SOLENOID.....	Standard
OPERATING FUEL PRESSURE.....	.5" - 14" H <sub>2</sub> O

## ELECTRICAL SYSTEM

BATTERY CHARGE ALTERNATOR.....	12V 30 Amp
STATIC BATTERY CHARGER.....	2 Amp
RECOMMENDED BATTERY.....	Group 24F, 525CCA
SYSTEM VOLTAGE.....	12 Volts

## OPERATING DATA

		COMMERCIAL 45 kW		
KW RATING		45		
ENGINE SIZE		2.4 Liter		
GENERATOR OUTPUT VOLTAGE/KW - 60Hz		KW	AMP	CB Size
120/208V, 3-phase, 0.8 pf		45	156.3	175
120/240V, 3-phase, 0.8 pf		45	135.4	150
277/480V, 3-phase, 0.8 pf		45	67.7	80
GENERATOR LOCKED ROTOR KVA AVAILABLE @ VOLTAGE DIP OF 35%				
208 3-phase		100		
480V 3-phase		110		
ENGINE FUEL CONSUMPTION (Natural Gas) (Propane)		Natural Gas (ft <sup>3</sup> /hr.)	Propane (gal/hr.) cu ft/hr	
Exercise cycle		102	1.11	40.4
25% of rated load		194	2.12	77.1
50% of rated load		373	4.07	148
75% of rated load		520	5.67	206.3
100% of rated load		720	7.86	286
ENGINE COOLING				
Air flow (inlet air including alternator and combustion air)		ft <sup>3</sup> /min.	2,725	
System coolant capacity		US gal.	3.0	
Heat rejection to coolant		BTU/hr.	173,000	
Max. operating air temp. on radiator		°C (°F)	60 (150)	
Max. ambient temperature		°C (°F)	50 (140)	
COMBUSTION AIR REQUIREMENTS				
Flow at rated power 60 Hz		cfm	144	
SOUND EMISSIONS IN DBA				
Exercising at 7 meters		58		
Full load at 7 meters		72		
EXHAUST				
Exhaust flow at rated output 60 Hz		cfm	429	
Exhaust temp. at muffler outlet		°F	1150	
ENGINE PARAMETERS				
Rated synchronous RPM		60 Hz	3600	
HP at rated KW		60 Hz	71	
POWER ADJUSTMENT FOR AMBIENT CONDITIONS				
Temperature Deration				
3% for every 10 °C above - °C		25		
1.65% for every 10 °F above - °F		77		
Altitude Deration				
1% for every 100 m above - m		183		
3% for every 1000 ft. above - ft.		600		

RATING: All single phase units are rated at 1.0 power factor. STANDBY RATING: Standby ratings apply to installations served by a reliable utility source. The standby rating is applicable to varying loads for the duration of a power outage. There is no overload capability for this rating. Ratings are in accordance with ISO-3046-1. Design and specifications are subject to change without notice. Maximum wattage and current are subject to and limited by such factors as fuel Btu content, ambient temperature, altitude, engine power and condition, etc.

# INTERCONNECTIONS

COMMERCIAL 45 kW

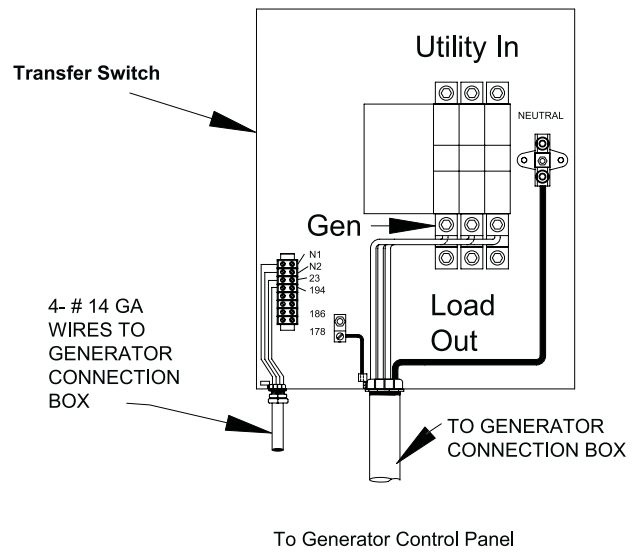
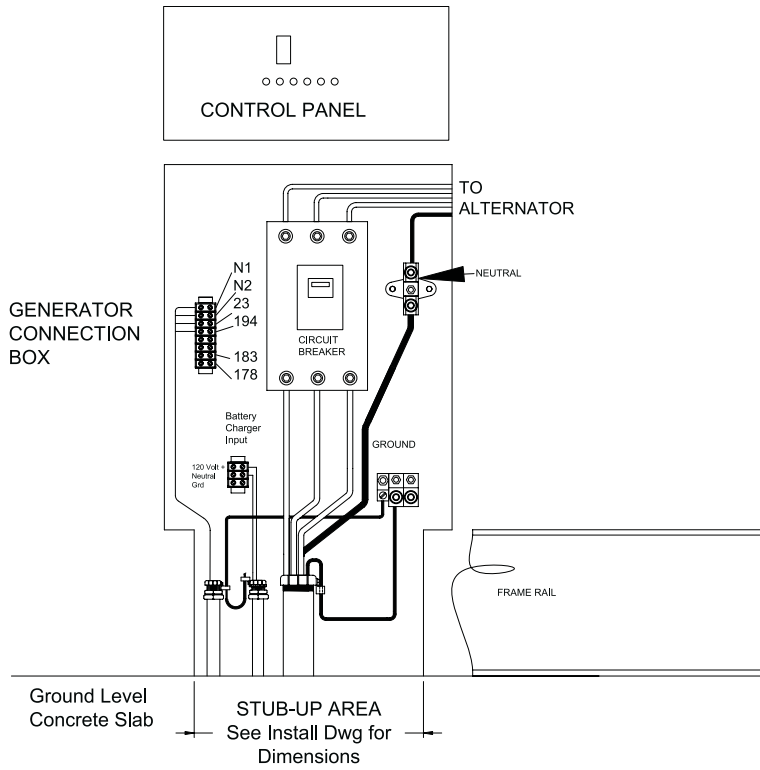

CIRCUIT BREAKER SIZE

KW	VOLTS	AMPS	LUG SIZE
45	208 3 $\phi$	175	#6 to 300 mcm
45	240 3 $\phi$	150	#6 to 300 mcm
45	480 3 $\phi$	80	#6 to 300 mcm

# INSTALLATION LAYOUT

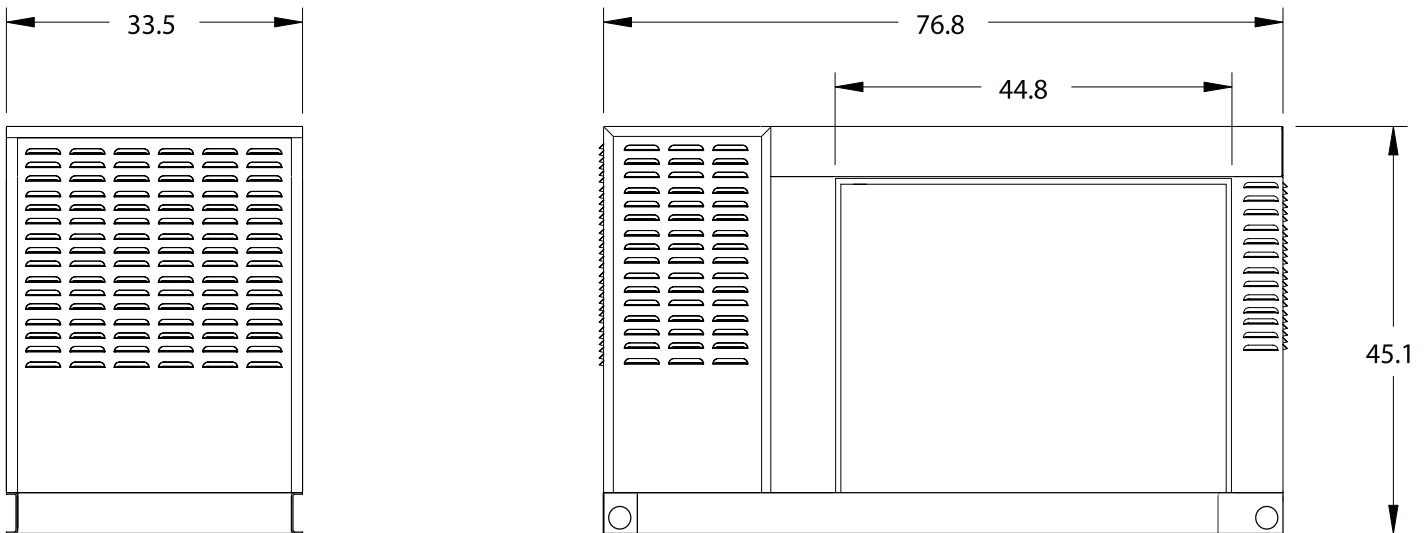

**UNIT WEIGHT: Steel 1414 lbs.**

**GENERAC**® POWER SYSTEMS, INC. • P.O. BOX 297 • WHITEWATER, WI 53190  
[www.guardiangenerators.com](http://www.guardiangenerators.com)